



GREEN TROUGH
TECHNICAL SPECIFICATION



Powered by  **FURUKAWA**
ELECTRIC GROUP



1. Scope

This specification applies to Troughs made by re-cycled synthetic resin (hereinafter called the “Green Trough”). It details the range of available parts and their respective dimensions for the 6 section sizes.

2. Structure

The structure and components of the straight Trough are as shown in Figures 1 & 2 and Table 1. Note that its grey colour tone is purposely designed to be similar to Concrete.

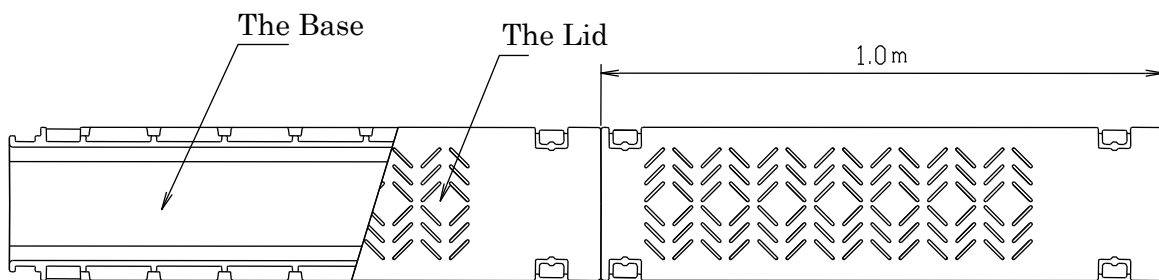

Figure 1. Structure (Assembly drawing of 90, 135, 150, 200, 300)

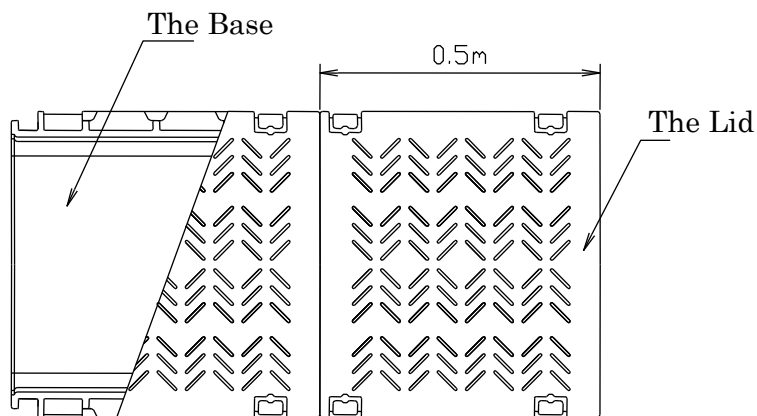

Figure 2. Structure (Assembly drawing of 430)

Table 1. Component

Item	Quantity	Material
The Lid	1 Piece	Basic material : Recycled Polyethylene (PE), Recycled Polypropylene (PP), Chemical agents (UV stabilisers, Anti-static, etc..), Inorganic filler, etc..
The Base	1 Piece	

Note, since Green Trough is made from recycled materials, the colour may vary from product to product. Even within the same Green Trough unit, colour unevenness may occur depending on the storage conditions, however, the colour unevenness will become less noticeable within a few weeks after installation.

3. Performance

The performance of the Trough is as shown in Table 2

Table 2 Performance

Item	Test method	Performance
Dimensions & Weight	4 . 1	As shown in Appendix
Compressive strength	4 . 2	In condition 4.9kN/0.5m, no crack or crevice shall appear in any part.
Flame retardance	4 . 3	After having removed the source flame in the fire-retardant test of JESC E 7003 (2005), it extinguishes on the product within 60 seconds.
Chemical resistance	4 . 4	A rate of weight change shall be 1% or less after soaking in water solution of 30%CaCl ₂ in a test method of JIS K 7114-IS0175
Operational temperature	4 . 5	- 40°C to 80°C
Weather resistance	4 . 6	50 years life span expected.

4. Test method

4.1 Dimensions & Weight

Each part (lid and base) of the trough will be measured with a steel tape measure at normal temperature (20±10 degrees Centigrade).

Each part of the trough will be weight using a scale at normal temperature (20±10 degrees Centigrade).

4.2 Compressive strength

As shown in Figure 3. , the trough with lid shall be added a linear load of more than 4.9kN/500 mm at a rate of 20 mm/min.

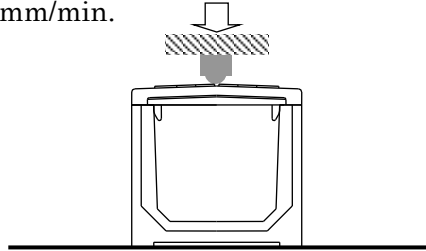

Figure 3. Illustration of compressive test

4.3 Flame retardance

Based on the test method of JESC E 7003 : 2005 ("flame retardance in combination with self-extinguishing properties", JESC : Japan Electro technical Standards and Codes Committee), a 300mm specimen is taken from the final product. The specimen is supported horizontally and the central part of the specimen is burnt with a Bunsen burner, which has a 130mm oxidizing flame. After having removed the flame, the flame should disappear spontaneously within 60 seconds.

4.4 Chemical resistance

According to the test method of JIS K 7114 – ISO 175 (Chemical resistance test), a specimen is taken from the final product. The specimen is soaked in a 30% calcium chloride water solution for 24 hours. The specimen mass is measured before and after the test. The weight change is measured according to the following calculation:

$$M = \frac{M2 - M1}{M1} \times 100$$

M : A rate of weight change [%]
 M1 : A mass of the specimen before the test [mg]
 M2 : A mass of the specimen after the test [mg]

4.5 Operational temperature

A specimen of Green Trough was exposed to a temperature cycling between -40°C and 80°C. After completion of the cycle, the specimen was checked for any visible signs of cracks and the locking mechanism checked for normal operation.

4.5 Weather resistance

A specimen based on JIS7161 and JIS7162 was irradiated with Super UV by using an accelerated weather resistance test machine. The strength of Green Trough was checked at various intervals using the “Tensile strength test” and “Charpy impact test”.

5. Locking mechanism

Two locking mechanisms are available for the Green Trough, screw type and clip type. Screw type Green Trough is the standard system sold; its characteristics are detailed in appendix 5. The clip type Green Trough system is only available upon request.

As a result, the part number used in this document denote for the screw type system. The part number for a clip type trough would start by “TC” instead of “TS”; e.g. TC200S denotes for a 200 series straight trough with a clip type locking mechanism, while TS200S denotes for a 200 series straight trough with a screw type locking mechanism.

6. Certification

Network Rail: Product acceptance number PA05/05145

London Underground: Registration number 5037

7. Environmental Information

An Environmental Product Declaration (**EPD**) is available upon request.

The Appendices on the following pages detail the sizing and part numbers for the available units in the range.

Please note that the Green Trough accessories (such as are Elevated Solution and our Walkway System) are listed onto separate specification documents. These are available on our website www.hirdtts.com or on request at ttsinfo@hird.group

Appendix 1 Standard Straight Trough

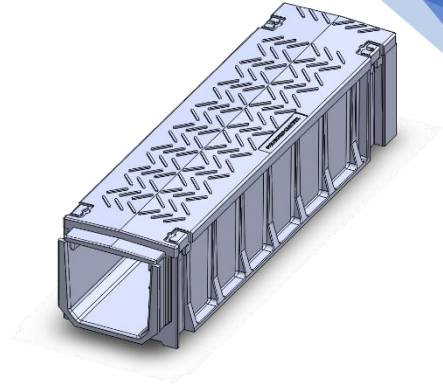

Inner surface
of the Trough

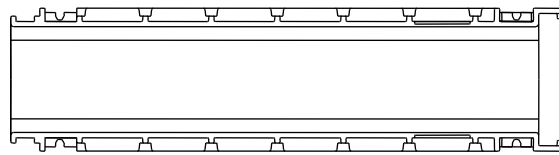

For screw
(2 pcs/set)

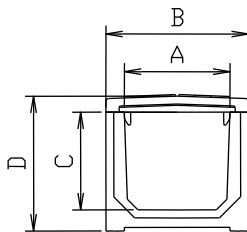
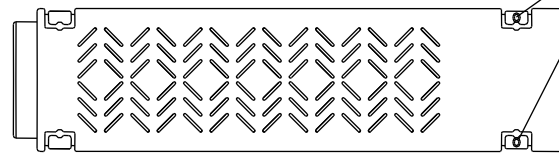

Lid

Base

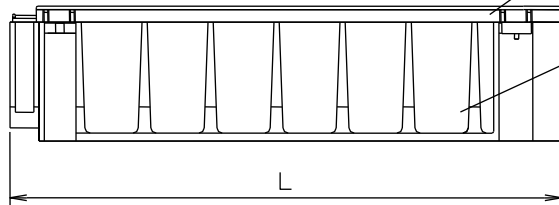

Series	Part No.	NR Cat No.	A (mm)	B (mm)	C (mm)	D (mm)	L (mm)	Base Wt. (kg)	Lid Wt. (kg)
090	TS090S	087/004935	90±8	120±8	100±8	136±10	1035 ⁺³⁰ ₋₁₀	4±0.5	3±0.5
135	TS135S	087/004936	135±8	170±8	125±8	170±10	1035 ⁺³⁰ ₋₁₀	6±0.5	4±0.5
150	TS150S	087/004701	160±8	210±8	135±8	190±10	1035 ⁺³⁰ ₋₁₀	8±0.5	5±0.5
200	TS200S	087/004702	200±8	270±8	185±8	255±10	1045 ⁺³⁰ ₋₁₀	14±0.5	7±0.5
300	TS300S	087/004705	300±8	390±8	175±8	265±10	1045 ⁺³⁰ ₋₁₀	17±0.5	12±0.5
430	TS430S	087/004707	450±8	540±8	255±8	360±10	545 ⁺³⁰ ₋₁₀	15±0.5	9±0.5

Appendix 2 45-degree angle trough

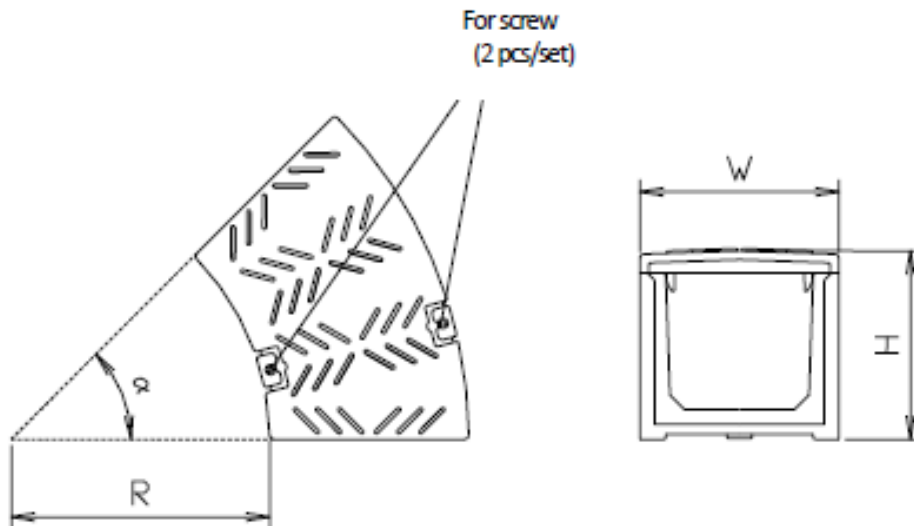
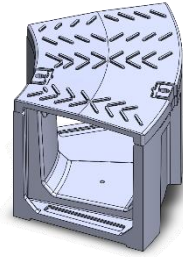

Series	Part No.	NR Cat No.	W (mm)	H (mm)	α	R (mm)	Base Wt. (kg)	Lid Wt. (kg)
090	TS090B	087/004941	120±8	136±8	45°	350	2±0.5	1±0.5
135	TS135B	087/004942	170±8	170±10			2±0.5	2±0.5
150	TS150B	087/004731	210±8	190±10			3±0.5	2±0.5
200	TS200B	087/004732	270±8	255±10			6±0.5	2±0.5
300	TS300B	087/004734	390±8	265±10			8±0.5	5±0.5
430	TS430B	087/004735	540±8	360±10			12±0.5	7±0.5

Accessory : Male-male adaptor : 1 set (2pcs) supplied

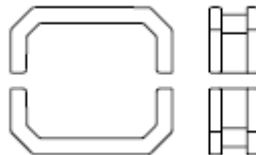

Appendix 3 T - Junction Trough

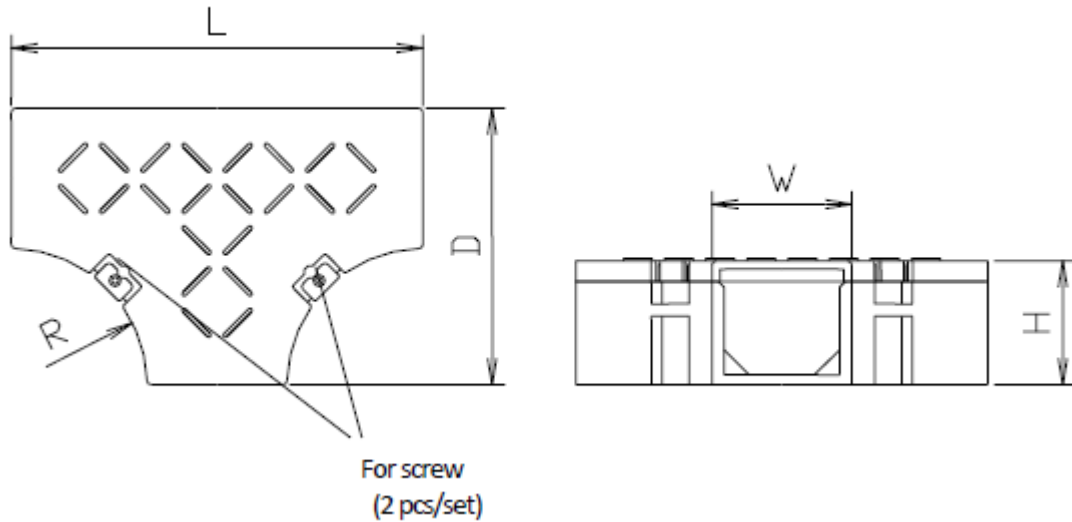
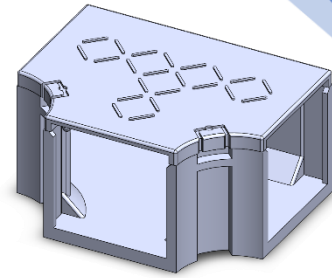

Series	Part No.	NR Cat No.	L (mm)	D (mm)	W (mm)	H (mm)	R (mm)	Base Wt. (kg)	Lid Wt. (kg)
090	TS090T	087/004943	600±8	360±8	120±8	136±10	190	4	2
135	TS135T	087/004944	600±8	385±8	170±8	170±10	165	5	3
150	TS150T	087/004737	500±8	355±8	210±8	190±10	145	5	4
200	TS200T	087/004738	500±8	385±8	270±8	255±10	115	9	4
300	TS300T	087/004740	600±8	495±8	390±8	265±10	105	13	8
430	TS430T	087/004643	730±8	635±8	540±8	360±10	80	21	14

Accessory : Male-male adaptor : 1 set (2pcs) supplied

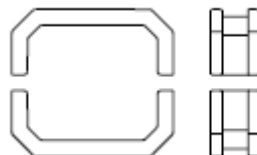

Appendix 4 Gradient trough

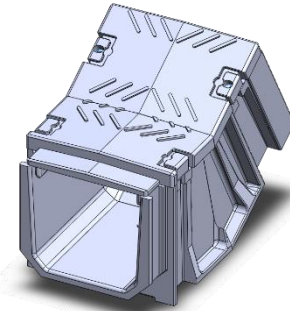

Gradient trough (Up)

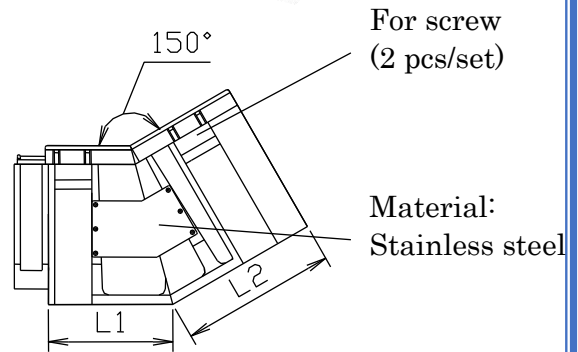
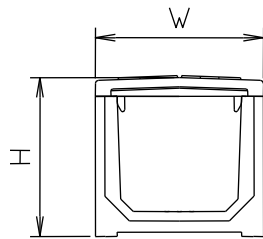

Gradient trough (Down)

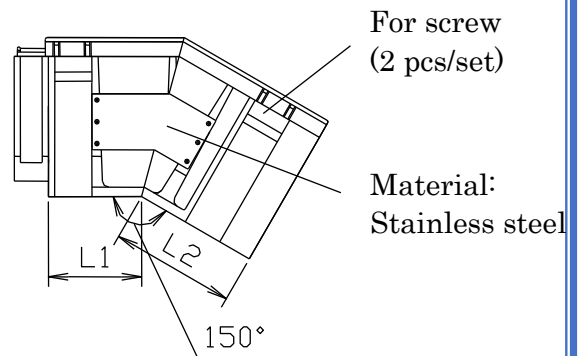
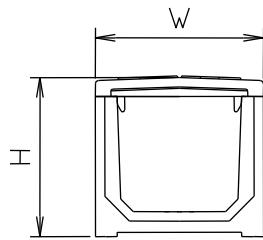

(Unit : mm)

Part name	Series	Part No.	NR Cat No.	W	H	L1	L2
Gradient trough(UP)	090	TS090U	087/004937	120±8	136±10	300±10	350±10
	135	TS135U	087/004938	170±8	170±10		
	150	TS150U	087/004720	210±8	190±10		
	200	TS200U	087/004721	270±8	255±10	200±10	250±10
	300	TS300U	087/004723	390±8	265±10	322±10	277±10
	430	TS430U	087/004638	540±8	360±10		
Gradient trough(Down)	090	TS090D	087/004939	120±8	136±10	250±10	300±10
	135	TS135D	087/004940	170±8	170±10		
	150	TS150D	087/004726	210±8	190±10		
	200	TS200D	087/004727	270±8	255±10	150±10	200±10
	300	TS300D	087/004729	390±8	265±10		
	430	TS430D	087/004640	540±8	360±10	223±10	178±10

Appendix 5 Screw

Hexagonal head fitting
supplied as standard.

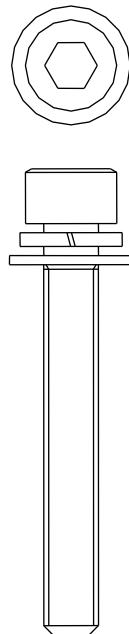

Other head types available upon request

Examples:

- Snake eye
- Pig nose

Size	Part No.	Type of Screw	Material
For 90,135	GT-BS20	CAP SEMS P3 M5L20	Stainless steel
For 150, 200, 300, 430	GT-BS45	CAP SEMS P3 M6L45	

Use for Straight Trough, 45-degree Bend Trough, T-junction Trough and Gradient trough (UP & Down).

2 screws required per trough unit.

Appendix 5 Concrete comparator chart

Conventional concrete sizes, internal capacity and weights



Comparable

TTS sizes, internal capacity and weights



Concrete code	Ext Width mm	Ext Depth mm	Internal capacity CSA mm ²	Weight (inc lid) Kg	TTS code	Ext Width mm	Ext Depth mm	Internal capacity CSA mm ²	Weight (inc lid) Kg	TTS capacity v Concrete
C/1/6	190	170	7500	59	90	120	136	9000	7	+20%
C/1/7	220	210	14950	76	135	170	170	16875	10	+13%
C/1/7	220	210	14950	76	150	210	190	20250	13	+44%
C/1/8	250	280	27750	100	200	270	255	37000	21	+33%
C/1/9	280	210	21850	88	150	210	190	20250	13	-1%
C/1/9	280	210	21850	88	200	270	255	37000	21	+69%
C/1/10	340	210	28750	104	300	390	265	52500	27	+83%
C/1/29	440	220	40250	137.2	300	390	265	52500	27	+30%
C/1/43	440	390	99750	180.8	430	540	360	114750	24*	+15%

* Denotes 0.5m length

For further information, please contact us on

Tel: 01302 343633

Email: ttsinfo@hird.group